

Products Introduction

PXF2

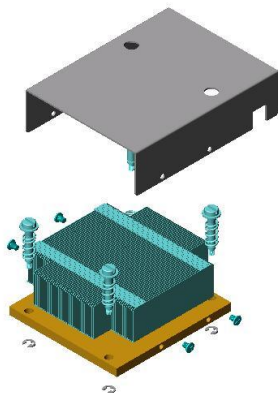

SPECIFICATION :

For Intel Xeon 3.2GHz

Thermal Resistance : 0.3 °C/W

Dimension:

- 1) heat sink: 85(L)x80(W)x27(H)mm
- 2) System fan : 40 x 40 x 28mm x 2 pcs

System Fan Specification :

- 1) Speed : 13000 rpm
- 2) Voltage : 12V
- 3) Air Flow : 21 CFM
- 4) Bearing : Dual Ball Bearing

Heat Sink Material : Cu Base, Cu Fin

Interface Material : Dow Corning SC102

Weight : 640 g

Spring Screw Retention Force : 24 lbf

DRAWING

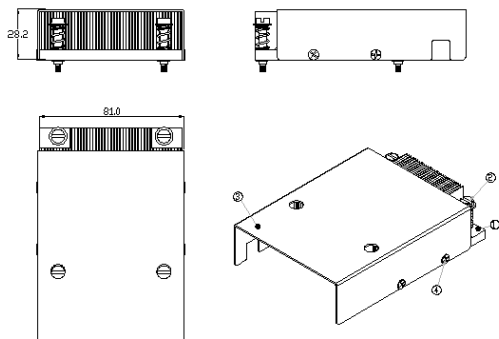

Thermal Performance with Airflow

Rth (°C /W) is between HIS and ambient air

Cross-section of air duct is 80 x 27 mm

